

Digital Cellular Modem-200 (DCM-200)

Cellular Radio Conversion Guide

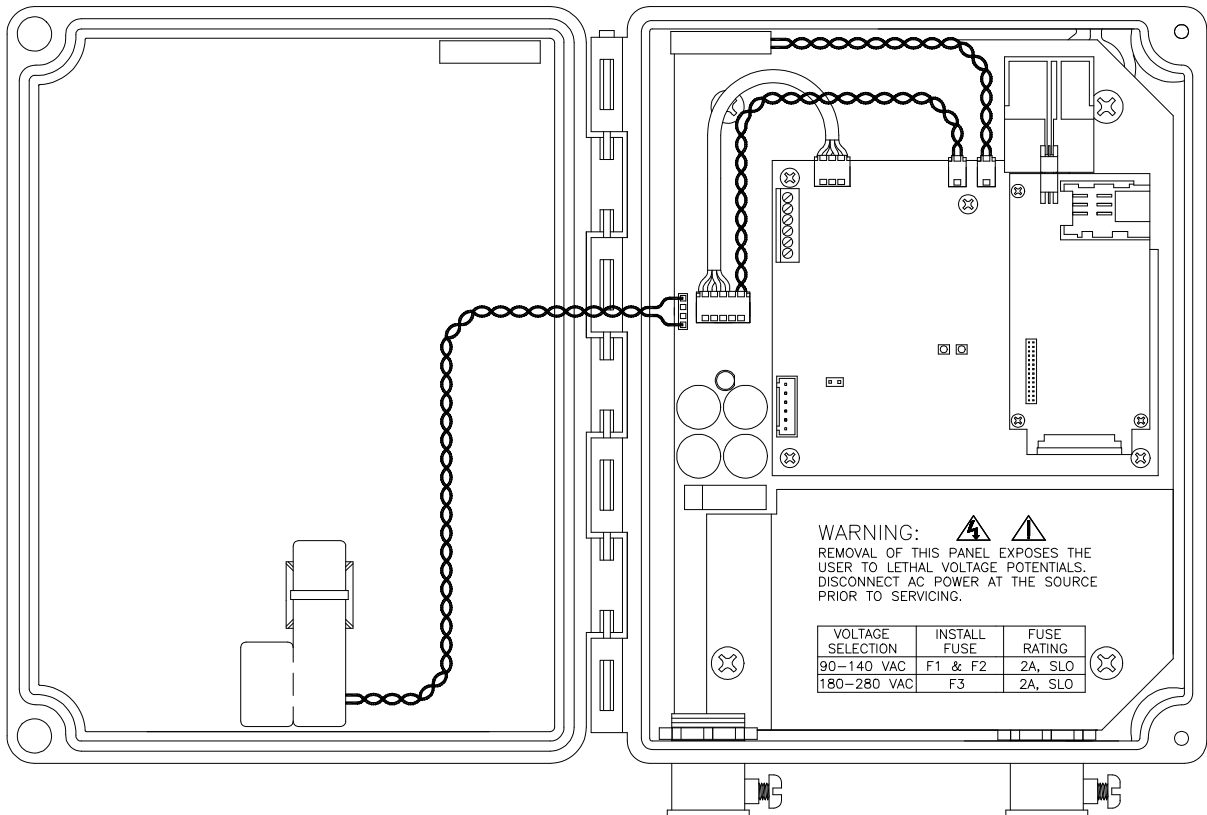

Document: 900363

Revision: B

March, 2006

TABLE OF CONTENTS

1	OVERVIEW	1-1
1.1	Product Description.....	1-1
1.2	Description of Problem.....	1-1
1.3	Required Materials.....	1-1
2	RADIO REPLACEMENT INSTRUCTIONS	2-1
2.1	DCM-200 Circuit Board Layout	2-1
2.2	Loading New Firmware	2-1
2.3	Removal of the g18 Radio.....	2-2
2.4	Installation of the g20 Adapter Assembly	2-3
2.5	Power-Up Check.....	2-5

LIST OF FIGURES

Metretek Programmer Cable	1-1
g18-to-g20 Conversion Assembly (without antenna)	1-2
1015-0208-001 Quad-band Antenna (optional)	1-2
Primary Components of the DCM-200.....	2-1
Location of Power Connector	2-2
Location of Radio Mounting Screws	2-2
Removal of Antenna and SIM Card.....	2-3
Alignment of Adapter Assembly	2-3
Installing Mounting Hardware.....	2-4
Installing the Quad-Band Antenna.....	2-4
Installation of Antenna and SIM Card.....	2-5
Reconnection of Power	2-5

COPYRIGHT ©2006 by Metretek, Incorporated

All rights to this document, domestic and international, are reserved by Metretek, Incorporated. No part of this publication may be reproduced, stored in a retrieval system, or transmitted in any form or by any means (electronic, mechanical, photocopying, recording, or otherwise) without the prior written permission of Metretek, Incorporated. Requests for permission to reproduce or distribute this manual should be addressed to:

METRETEK, INCORPORATED
305A EAST DRIVE
MELBOURNE, FLORIDA, USA 32904

1 OVERVIEW

1.1 Product Description

Metretek's DCM-200 is a wireless system designed to connect to an ANSI C12-19 compliant electric meter and transfer its information over the Internet using common GSM digital cellular phone networks.

1.2 Description of Problem

The original DCM-200 used a Motorola "g18" GSM cellular radio module. Production of this device was discontinued in 2005 and was replaced by the "g20". However, the g20 is not a drop-in replacement for the g18. Metretek has created an adapter assembly that allows g18s to be replaced with g20 radios with minimal effort and cost.

The original g18 radio supported three frequency bands, only one of which (1900 MHz) is used in North America. The original analog cellular services which existed on the 850 MHz band are quickly being discontinued and these cellular systems are now being converted to digital. Another benefit to using a g20 radio is that it supports both the 850 and 1900 MHz bands. This is important if cellular providers are going to change existing 1900 MHz service areas to 850 MHz.

1.3 Required Materials

- Metretek's MP32 configuration software, Version 3.4.1 or later. This is required to load new firmware into the DCM-200 to support the change from the g18 to the g20 radio.
- Programming adapter cable as illustrated in Figure 1-1. Metretek part number 1002-0299C-001.

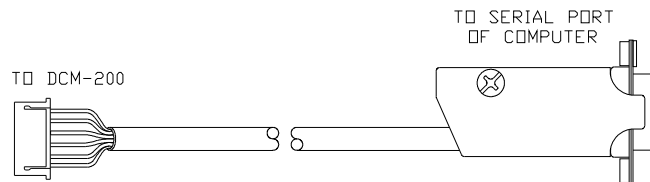

Figure 1-1
Metretek Programmer Cable

- DCM-200 Operator's Manual 900333. This manual contains instructions for loading new firmware into the DCM-200.
- #1 and #2 Philips-head screwdriver.
- Metretek 1001-0321-002 adapter assembly as shown in Figure 1-2.
- Metretek 1015-0208-001 quad-band antenna as shown in Figure 1-3. The use of this antenna may not be necessary if the cellular service will continue to be

provided on the 1900 MHz band only.

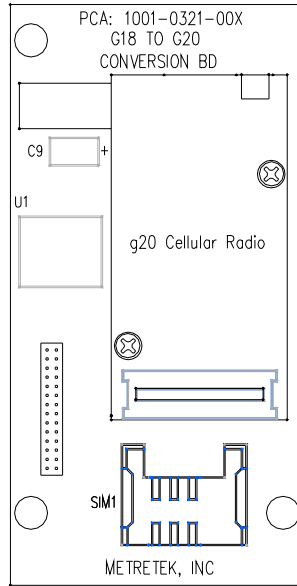

Figure 1-2
g18-to-g20 Conversion Assembly (without antenna)

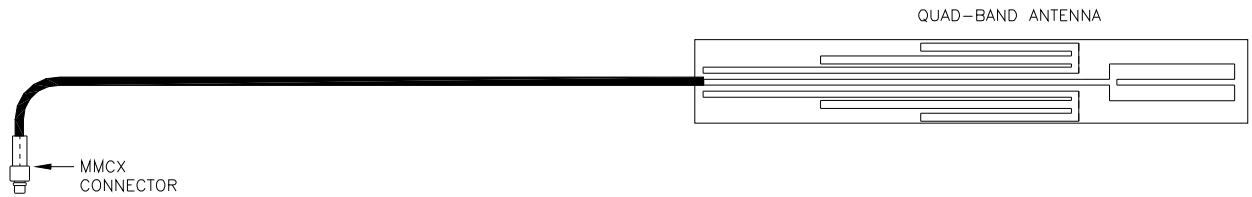

Figure 1-3
1015-0208-001 Quad-band Antenna (optional)

2 RADIO REPLACEMENT INSTRUCTIONS

2.1 DCM-200 Circuit Board Layout

The original DCM-200 circuit board assembly is shown in Figure 2-1. This board is attached to a larger power supply board (not shown). It is not necessary to remove any boards from the enclosure.

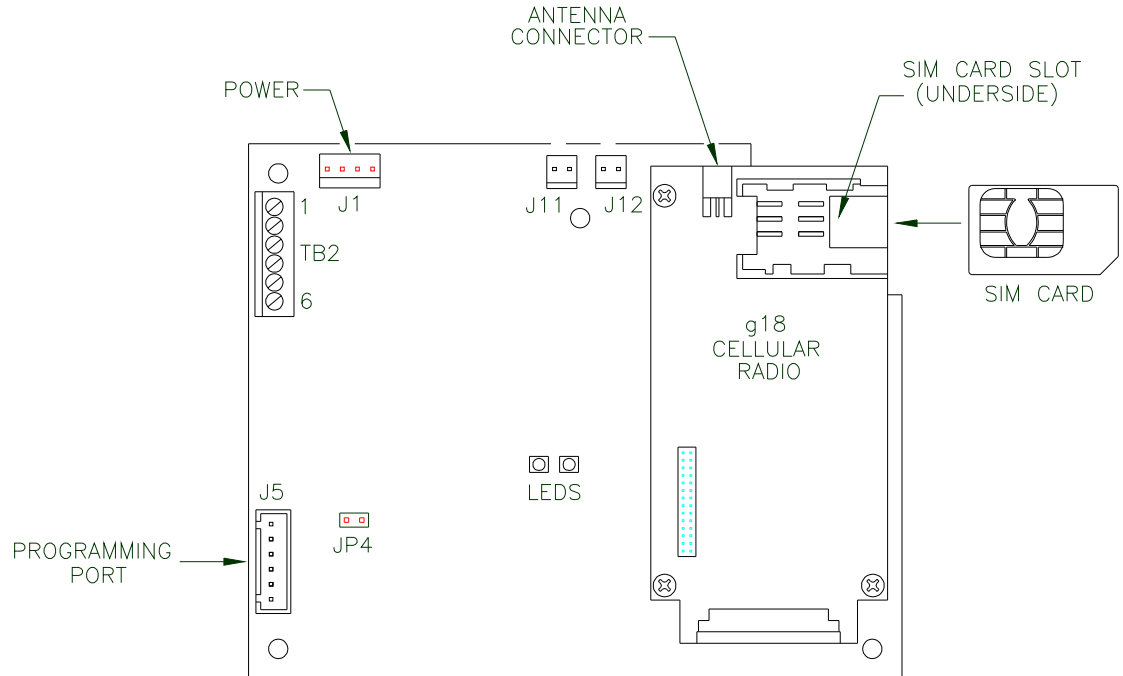

Figure 2-1
Primary Components of the DCM-200

2.2 Loading New Firmware

Prior to replacing the radio, the DCM-200 will need new operating software (“firmware”) to accept the g20 radio. Document 900333 describes this process in detail. The programming cable shown in Figure 1-1 is required.

The required firmware is 100219, Version V2.4 or later. The name of the program file for V2.4 is “100219_24.hex”.

2.3 Removal of the g18 Radio

- 1) Disconnect the power cable from the J1 connector.

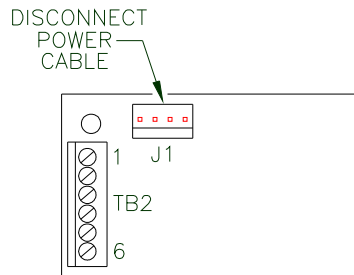

Figure 2-2
Location of Power Connector

- 2) Remove the three screws from the g18 radio. Save these, the three nylon washers and three nylon spacers for later use.

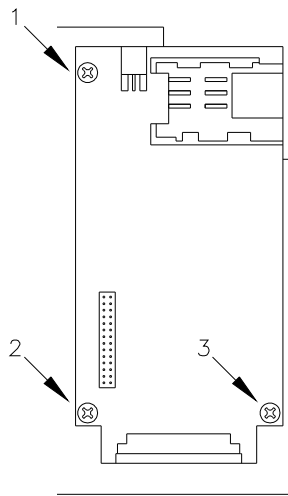

Figure 2-3
Location of Radio Mounting Screws

- 3) Gently remove the antenna or antenna cable by pulling it straight out. Remove the SIM card from the bottom of the radio.

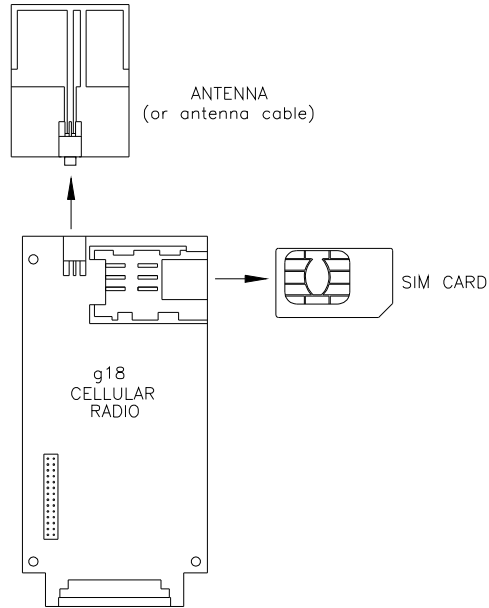

Figure 2-4
Removal of Antenna and SIM Card

2.4 Installation of the g20 Adapter Assembly

- 1) Align the three mounting holes of the adapter assembly over the three nuts in the DCM-200 board. Inspect the alignment of the 20-pin connectors on the adapter board and the DCM-200 board. Gently insert the interface connectors together.

Make certain that all pins are properly inserted into the connector on the adapter board. Failure to do so may cause damage to the radio or the DCM-200 board !

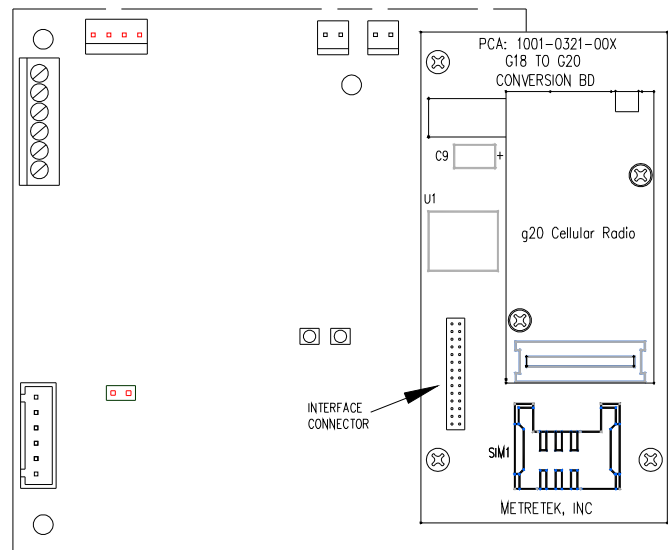

Figure 2-5
Alignment of Adapter Assembly

- 2) Reinstall the original three screws, spacers and washers as shown in Figure 2-6. The DCM-200 board already has non-removable nuts built in to the board.

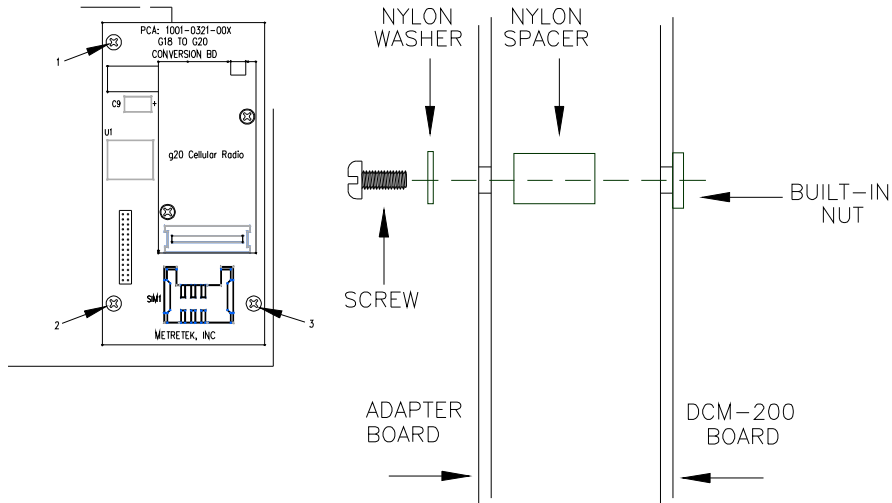

Figure 2-6
Installing Mounting Hardware

- 3) If the original antenna is going to be replaced by the quad-band antenna (shown in Figure 1-3), then refer to the next figure.

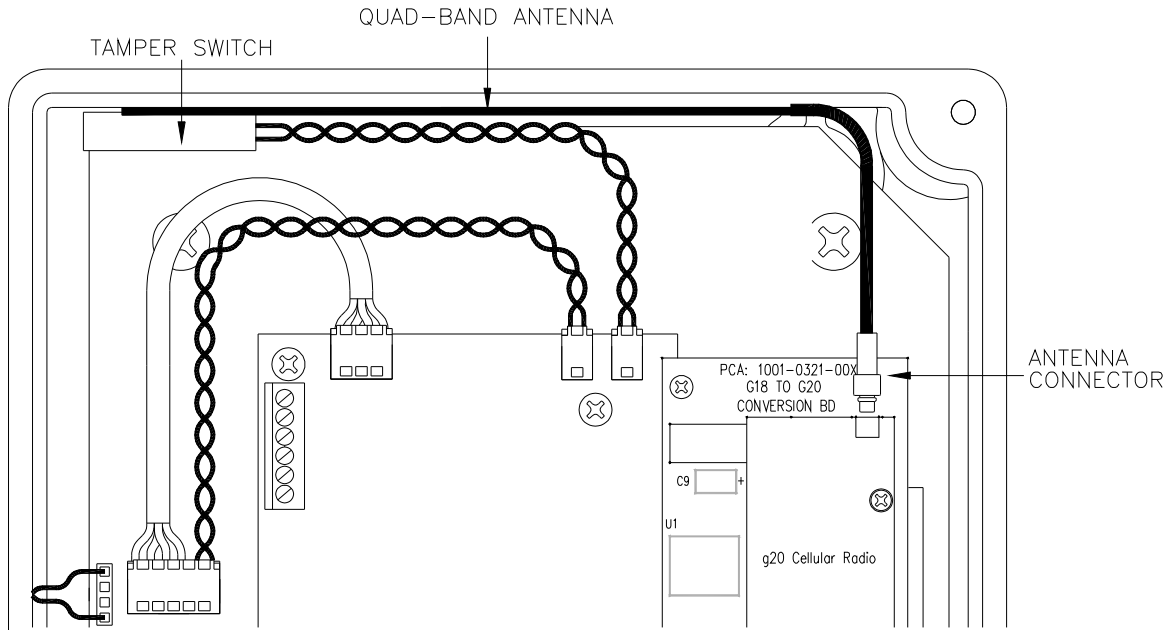

Figure 2-7
Installing the Quad-Band Antenna

Remove the paper backing from the adhesive strip on the back of the antenna. Position the antenna on the top inside wall of the enclosure just behind the Tamper switch as

shown in Figure 2-7. The antenna cable must exit to the right. Apply pressure for several seconds to ensure good adhesion.

4) Reinstall the original antenna (or the antenna cable from the quad-band antenna) by pushing straight into the antenna connector on the g20 radio until a “click” is heard. Install the SIM card observing that the notch is facing out as shown in Figure 2-8.

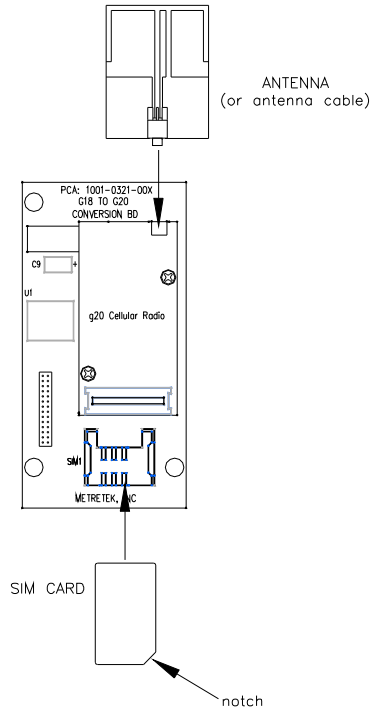

Figure 2-8
Installation of Antenna and SIM Card

5) Reconnect the power cable to the J1 connector.

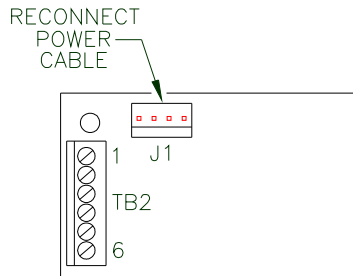

Figure 2-9
Reconnection of Power

2.5 Power-Up Check

The unit should behave exactly as it did with the g18 radio. Document 900333 describes this behavior.

