

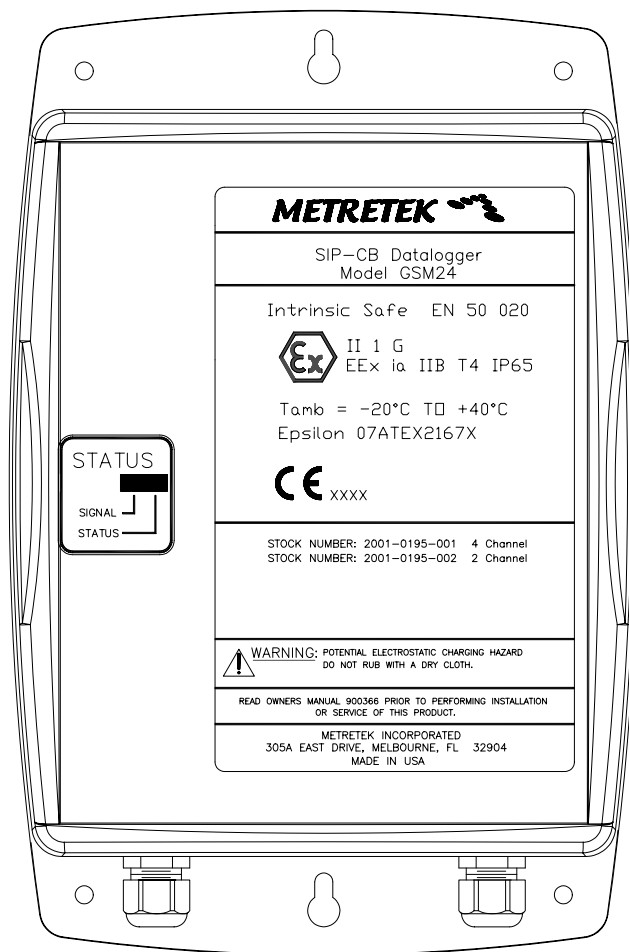

# APPLICATION NOTE

## USING THE INPUT SAMPLING MODE

### Survey Instrument Point - Cellular / Battery (SIP-CB)



Document: 600068  
Revision: A  
Aug 10, 2007

## INTRODUCTION

Metretek's SIP-CB is a battery-operated wireless data logger. One way to reduce power consumption and increase battery life is to use "*pulsed sample current*". See the User's Manual 900366 for a full description of the SIP-CB. See Application Note 600067 about ways to estimate and increase battery life.

## INPUTS VERSUS POWER CONSUMPTION

The SIP-CB can be connected to up to 8 external switch contacts. It can interpret these signals as alarm or status events, or can count and record the number of times the signals change in pulse-counting (metering) applications. The switches can be Form-A (normally-open), Form-B (normally-closed) or Form-C (a combination of a Form-A and Form-B switch in a single package).

In order for a switch event to be recognized a small amount of current must pass through the switch contacts. This is called "wetting current" and is 100  $\mu\text{A}$  (0.0001A) *per input*. Current is only consumed when the switch closes, as shown in Figure-1.

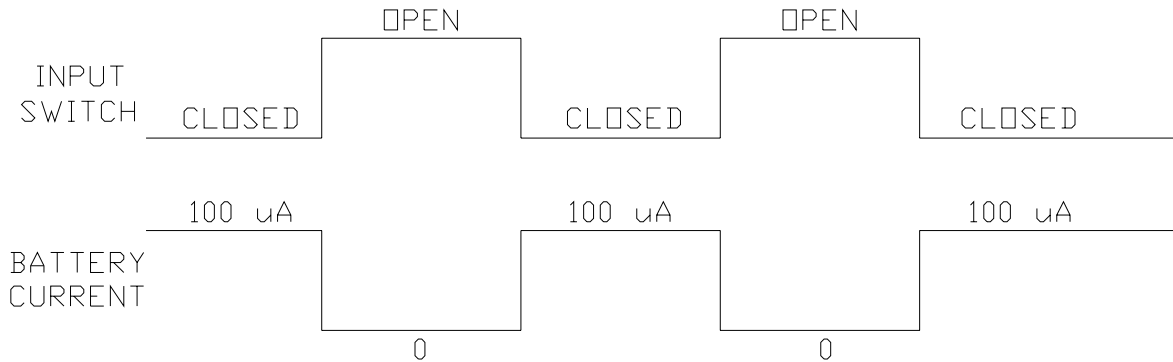

Figure-1  
Example of Wetting Current Cycles

The "duty cycle" is the ratio of the amount of time the switch is in one state versus the amount of time it's in both states. Figure-1 shows a 50% duty cycle. Assuming all 8 inputs are like this, a total of 3.5 A/hr of battery capacity will be consumed each year (100  $\mu\text{A}$  x 8 switches x 50% duty cycle x 24 hours per day x 365 days per year).

The worst-case scenario would occur if all 8 inputs were closed all of the time. In this case the battery consumption would be nearly 7.0 A/hr per year. The best case would occur if all inputs were open all of the time. The annual consumption would be nearly 0 A/hr.

## WHAT IS INPUT SAMPLING?

The SIP-CB does not inspect the state of the inputs 100% of the time; otherwise it wouldn't have time to perform any other functions. Rather the SIP-CB briefly inspects ("samples") the condition of the lines one or more times each second. You can configure the SIP-CB to take as few as one sample per second or as many as 50 samples per second. The 8 inputs are divided into two groups, each with its own sampling rate. The sampling process is illustrated in Figure-2.

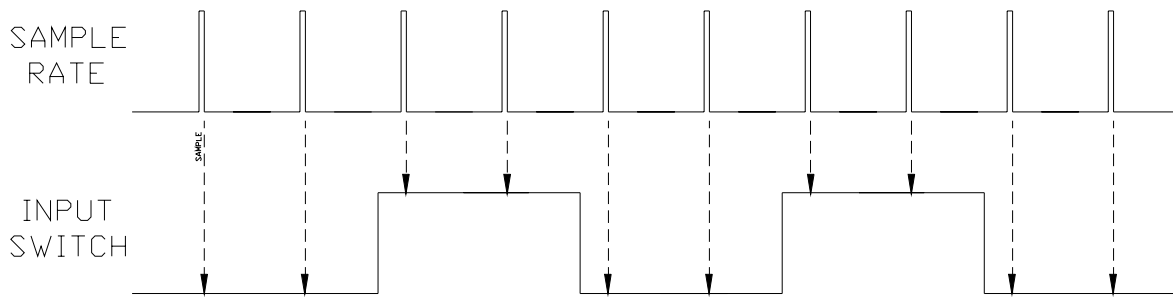

Figure-2  
Example of Sampling

The sample rate is based on how quickly you expect the inputs to change. Faster sampling rates are used for quickly-changing inputs but results in slightly higher power consumption (the SIP-CB has less time to enter its low-power sleep mode between samples). Too slow of a sampling rate can lead to errors, as shown next.

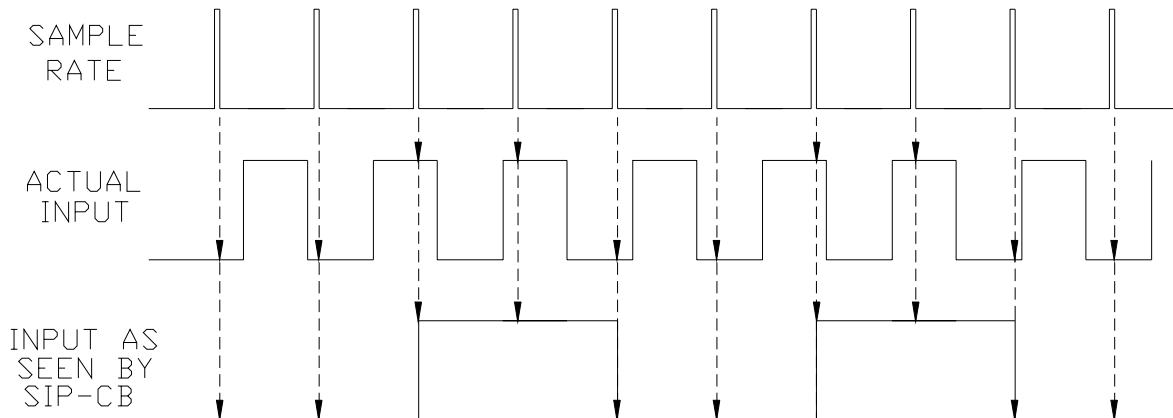

Figure-3  
Errors due to Slow Sample Rate

## WHAT IS SWITCH "BOUNCE"?

If you strike a hard surface with a stick it is likely to bounce a few times before coming to rest. The same is true for most mechanical switches. As the contacts come together they may open and close a few times, then finally settle in the closed position. This "bouncing" may be falsely interpreted as several events rather than just one. If the SIP-CB is counting pulses from this switch it might interpret the bounce as two or three pulses rather than just one. This is shown in Figure-4.

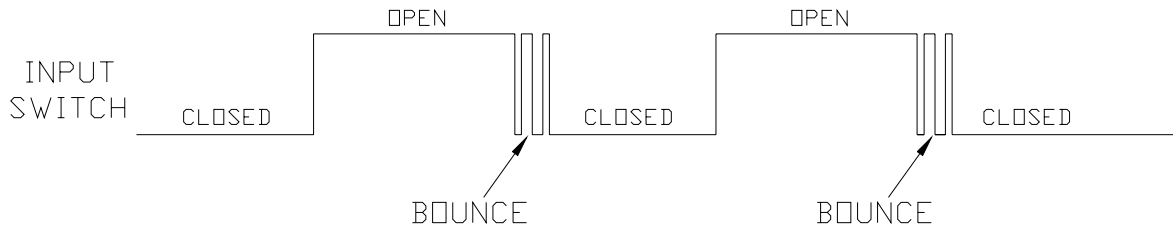

Figure-4  
Example of Switch Bounce

## WHAT IS SWITCH "DEBOUNCING"?

The process of "debouncing" requires the switch be in the same state over a specific number of samples to be considered "valid". Therefore the *debounce count* and the *sample rate* are directly related. If the input line changes states within this period of time the event is ignored and a new debounce period is started.

For example suppose the debounce count is set to 4 as shown in Figure-5. You can see that the first change was invalidated because it changed again before 4 samples had occurred. Later it changes again but stayed that way for at least 4 sample periods, so it was declared valid.

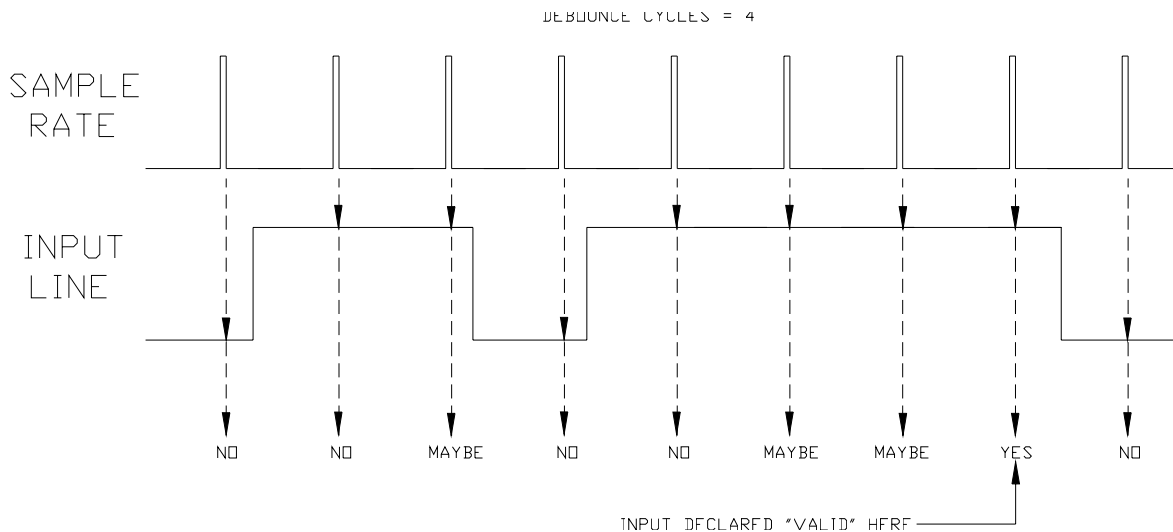

Figure-5  
Example of the Debouncing Process

You can also specify 0 as the debounce count. This will result in the fastest recognition of a change. As soon as the input changes from one state to another it is considered “valid”. But this may also lead to inaccurate results if the switch bounces a lot. This setting is normally used with non-mechanical switches such as transistors because they do not exhibit bounce problems.

### USING PULSED WETTING CURRENT

The wetting current is really only needed during the time that the SIP-CB is sampling the inputs. Otherwise it can be turned off to conserve power. This is illustrated in Figure-6. Now instead of each input drawing 100  $\mu\text{A}$  for 50% of the time (as was seen in Figure-1), it is only drawing it in very short bursts, perhaps 5% of the time.

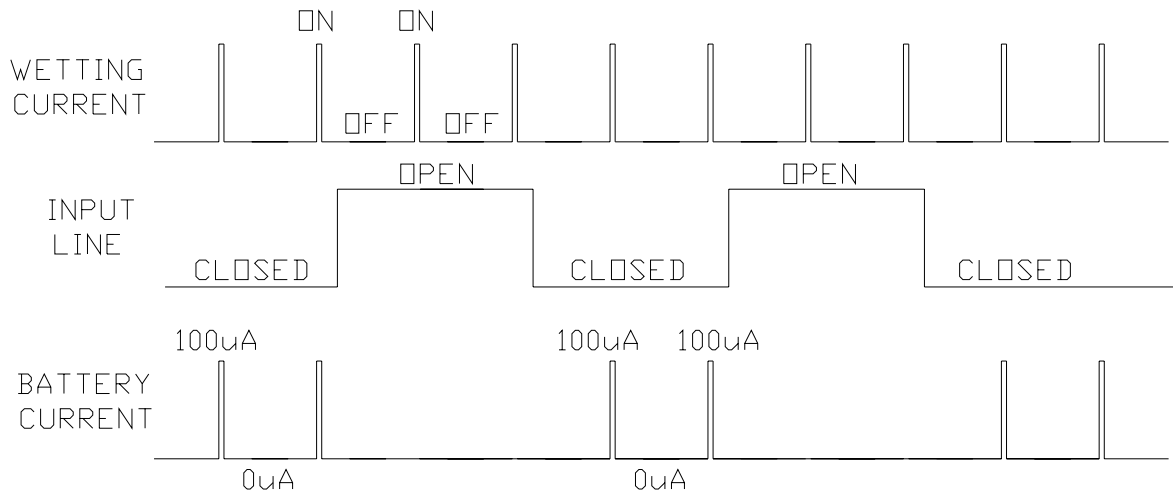

Figure-6  
Using Pulsed Wetting Current to Reduce Power Consumption

It does not take a lot of time for the SIP-CB to sample an input, so the wetting current does not have to be turned on for very long. Each group of lines has its own wetting current control circuit, so a unique pulse width can be assigned to each group.

The sample is taken just before the wetting current is turned back off. Generally a pulse width of 2.0 – 2.5 mS works in most applications. Excessively long cables or wiring that is connected to voltage protection devices might require a longer sampling pulse width in order to obtain accurate readings. These conditions may delay or distort the signal from the switch and cause inaccurate results if sampled too quickly. An example is shown in the next figure.

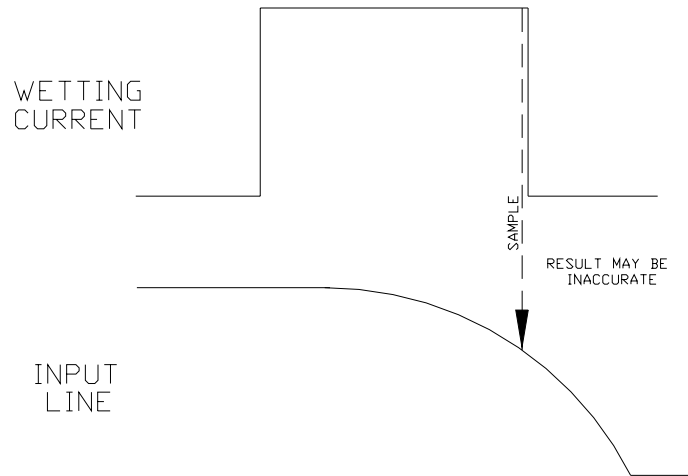

Figure-7  
Example of Sampling Error due to Signal Distortion

### EDGE-DETECTION MODE

Timed sampling mode allows you to optimize power consumption based on what you expect to see at any of the inputs, and to compensate for “bouncy” switches. But because the number of samples is limited to 50 per second, this places a limit on how fast the input signal can change and still be recognized.

Edge-detection mode allows faster signals to be recognized. However this mode requires that the wetting current remain on at all times. To enable edge-detection mode set both the *sample rate* and *pulse width* to 0. In this mode the *debounce cycles* setting is ignored and no debouncing takes place. This mode should not be used with “bouncy” switches.

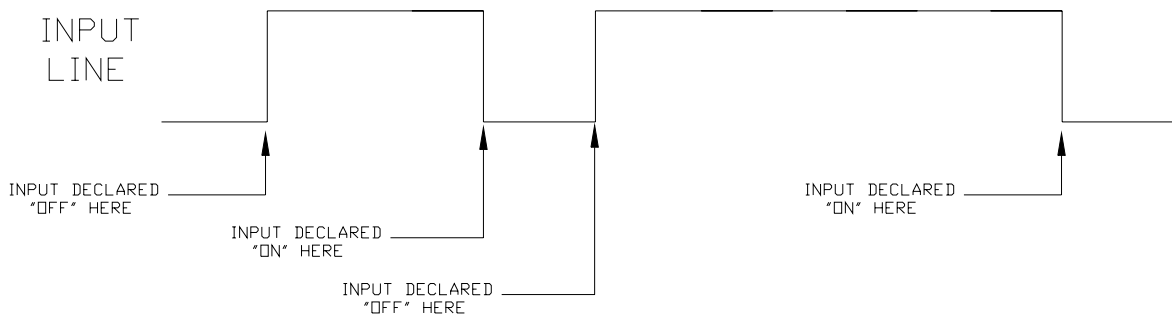

Figure-8  
Example of Edge Detection Process

## WHEN NOT TO USE PULSED WETTING CURRENT

Specifying a wetting current pulse width of 0 turns the wetting current on full time, as was illustrated back in Figure-1. There are a few reasons to do this:

- Some types of metering equipment may not be able to tolerate pulsed wetting current. You will have to consult with the manufacturer of the equipment about this.
- The use of edge-detection mode requires full-time wetting current.

## CHOOSING THE BEST COMBINATION OF SAMPLING PARAMETERS

Ultimately the purpose of pulsed wetting current is to minimize power consumption while still obtaining accurate pulse data and timely response to alarm events. Here are some general rules:

- Less frequent samples are better for battery life.
- Shorter wetting current pulse widths are better for battery life.
- If you are not sure what to do then choose 50 samples per second and a 2.5 mS pulse width for both input groups. This results in the best overall accuracy and response time. For the worst-case scenario (all 8 input switches closed all the time) the battery consumption will be 1.75 A/hr per year compared to 7.0 A/hr using continuous wetting current. Further reductions can be made by decreasing the sample rate and/or pulse width.
- If the shortest part of the input signal is less than 25 mS then you will need to use edge-detection mode. This mode can lead to errors when using “bouncy” switches.
- Generally alarm or status signals do not need to be processed as quickly as pulse-counting data. Therefore you can probably choose less frequent sample rates for alarm signals unless they are only active for a very short time.
- Remember that sample rate and debounce cycles are interrelated. All of the following settings will cause the input to be declared valid in 400 mS (0.4 seconds). But the 1st setting will result in the lowest power consumption.
  - 5 samples per second and 2 debounce cycles
  - 10 samples per second and 4 debounce cycles
  - 20 samples per second and 8 debounce cycles
- For best accuracy set the sample rate so that there are at least 2 samples within the shortest part of the input signal. See Figure-1 for a good example.